

carilex®



**CENTRIUS POWER UNIT
SERVICE MANUAL**

Table of Contents

General Information

Page

A. Introduction	03
B. Safety Precautions	04
C. Warnings	04



Maintenance – Level 1

Page

A. Introduction	06
B. Tools Required	06



Power Unit

A. Part Identification Overview	07
B. Setting Up and Switching On the Power Unit	08
C. General Pump Maintenance	09
D. General Cleaning Instructions	10
E. Air Inlet Maintenance	10
F. Replacing the Panel Foil	11
G. Replacing a Fuse	11
H. Replacing a Hanging Hook	12

Table of Contents

Maintenance and Repair – Level 2

Page

- A. Introduction..... 13
- B. Tools Required..... 13



Power Unit

- A. Part Identification Overview..... 14
- B. Replacing the Top Case..... 15
- C. Replacing the Control PCBA..... 16
- D. Replacing the Rotor Valve Assembly..... 16
- E. Re-lubricating the Rotor Valve Plates..... 17
- F. Replacing the Silicone Tube Set..... 18
- G. Replacing the Power PCBA..... 18
- H. Replacing the Compressor..... 19
- I. Replacing the Transformer..... 19
- J. Replacing the Battery Assembly..... 20
- K. Replacing the Side Panel Set..... 20
- L. Replacing the Bottom Case..... 21

Testing

Page

- A. Introduction..... 22
- B. Tools Required..... 22

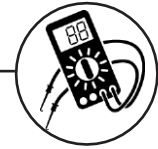

Power Unit

- A. Function Test..... 23
- B. Flow Test..... 24

Troubleshooting

Page

- A. Introduction..... 25
- B. Power Unit..... 26



Associated Forms

Page

- Product Service Record..... 27

General Information

A. Introduction

The Centrius Power Unit can be matched with the Entrix 5" M-Set, with the Entrix LUX M-Set and with the Fit M-Set.

This Carilex Service Manual provides repair and maintenance instructions for the Centrius Power Unit.

Any trained maintenance staff member can perform the procedures described in the sections of this manual that are designated Level 1.

Only manufacture-authorized service personnel can perform the procedures described in the sections of the manual that are designated Level 2.

If the system cannot be repaired using the procedures described in the Level 1 sections of this manual and there are no manufacture-authorized service personnel available, please contact Carilex or your local distributor to receive a return authorization number and a return address where the system can be sent for repair and servicing.

Indications:

The air alternating mattress system is designed for patients who endure pressure ulcer and potential patients who wish to reduce the likelihood of pressure ulcer. The device is intended to treat and prevent pressure ulcers by facilitating blood circulation and decreasing pressure of each tissue's contact area. Anti-decubitus Air Alternating Mattress Entrix System intended to treat and/or prevent decubitus ulcers otherwise known as bed sores, pressure sores, and pressure ulcers. Always consults a physician or health professional before using this device

Contraindications:

Certain patient conditions are not suitable for using this type of device such as fracture of instable vertebrae and illness of instable vertebrae. Always consult a physician or health professional before using this device. The use of this system does not replace the regular repositioning, monitoring, and nursing of the patient. Certain patient conditions (e.g. unstable cervical fracture, fracture of unstable vertebrae and illness of unstable vertebrae) are contraindicated for use with this device. Always consult a physician or health professional before using this device.

B. Safety Precautions

Installation:

Verify mattress anchor straps are attached to bed frame securely to ensure proper operation, inspect and verify air cells are upright and in place. Test all bed frame functions to verify no interference. Do not place anything on the power unit. Route power cord underneath bed frame and verify freedom from hazard.

Bed Linens:

This device incorporates a waterproof cover that is moisture vapor permeable; therefore, it is recommended to limit bed linens to one sheet in order to maximize the system's performance.

NOTE: Only "breathable" incontinent pads are recommended for use with this device.



Open Flames:

Do not expose this device to open flames, lighters, or cigarettes. This device draws room air continuously, therefore cigarette smoking is not recommended near this device. Cigarette smoke may damage internal components. Cigarettes may ignite bed linens.

CAUTION: DO NOT SMOKE CIGARETTES, PIPES, CIGARS, OR ANY OTHER RELATED PRODUCTS ON OR AROUND THIS SYSTEM. FLAMMABILITY HAZARD EXISTS.

C. Warnings



Cross Contamination:

This device should be decontaminated between patient installations. Refer to Power Unit and Mattress Maintenance Sections of this Manual for proper instructions. Failure to disinfect may result in cross contamination.



Weight Limitation

Verify that the patient weight, therapeutic support surface, bed rails, etc. do not exceed weight capacity of the bed frame. Verify patient weight does not exceed this device's weight capacity.



Entrapment:

When using side rails and/or assist devices, use a mattress thick enough and wide enough so that the gap between the top of the mattress and the bottom of the side rails and the gap between the side of the mattress and the side rails is small enough to prevent a patient from getting his or her head or neck between the mattress and the side rail. Failure to do so could result in serious patient injury or death.



Patient Falls:

Failure to use bed rails in raised position could lead to accidental patient falls. Air mattresses have soft edges that may collapse when patients roll to that edge.



Risk of Electric Shock:

DO NOT open back cover. This device is NOT user serviceable. This device should only be opened by qualified personnel approved by Carilex. Refer all service to your local Carilex authorized dealer.



Oxygen Equipment:

Explosion risk if used in the presence of flammable anesthetics.

**Fuse:**

Danger! Risk of fire. Replace fuses as marked: T1A/250VAC (Power Fuse).

**Electrical:**

Do not insert items into any opening of the power unit. This could short internal components, which could cause fire or electrical shock. This product is NOT AP/APG protected. REFER SERVICING TO QUALIFIED PERSONNEL ONLY.

**IP21:**

In accordance with the acceptance conditions as required by IEC 60529-V2.2:2013

**Class II product:**

This product is a Class II product. Do NOT cut or remove the grounding prong for shock prevention from the plug on this product if it is present. In the event that a non-compatible wall receptacle is found, it is the customer's personal responsibility and obligation to contact a qualified electrician to replace it with a compatible wall receptacle in accordance with the National Electrical Code.

**Extension Cord:**

If for any reason, you find it necessary to use an extension cord, ONLY use an appropriate extension cord that has the same or higher electrical rating as the device it is being connected to.

**Proper Mattress Set:**

The power unit and mattress are design to work together for patient's safety reason. Power unit should only be used with the correct mattresses recommended by the manufacture. Mismatching the power unit and mattress is strictly prohibited. Misusage may lead to patient risk.

**Hospital Grade receptacle:**

Note: Grounding reliability can only be achieved when the plug is connected to an equivalent receptacle marked "Hospital Grade" or "Hospital Only".

Maintenance - Level 1

A. Introduction

Any trained maintenance staff member can perform the procedures described in the sections of this manual that are designated Level 1.

B. Tools Required

- Philips PH2 Screwdriver 
- Wire Cutters 
- Sharp Knife 

Power Unit

A. Part Identification Overview



Fig: 1

B. Setting Up and Switching On the Power Unit

1. Use the hanging hooks (Fig: 1) to attach the power unit to the foot end of the bed.
2. Connect the CPC connectors from the mattress to the CPC assembly (Fig: 1) on the power unit.
3. Connect the power cable to the IEC socket (Fig: 1) and to a mains power supply ensuring that the power is switched on at the mains outlet.
4. Switch on the rocker switch on the side of the unit (Fig: 1).
5. Press the power button on the control panel to power on the power unit (Fig: 2).
6. The compressor will start, all of LEDs will light up and the green LED above the power button will flash.

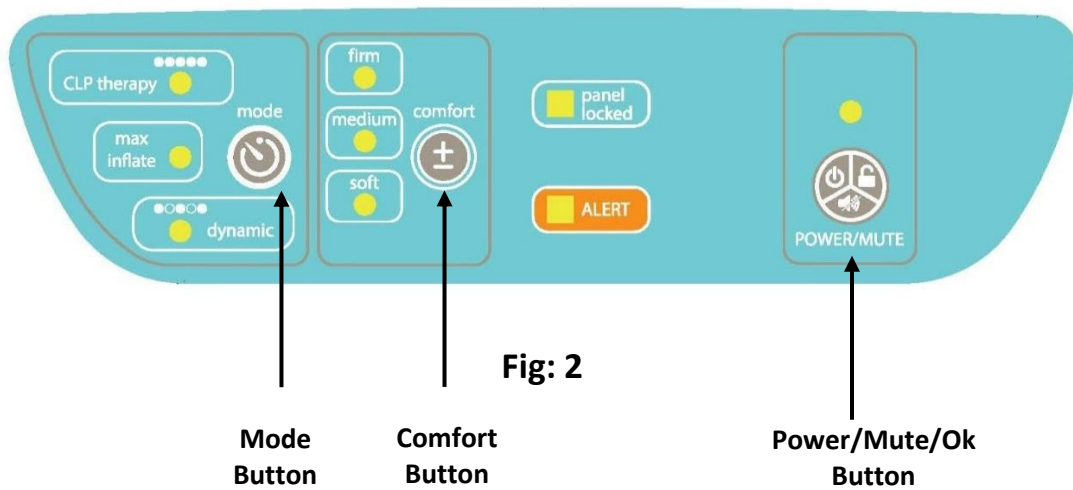

C. General Maintenance

Body and CPC Assembly

1. Thoroughly inspect the body casing and panel foil for any damage, such as cracks, where moisture might get inside.
2. Check that the control knob is present and check for damage, such as cracks.
3. Check the CPC assembly for damage that may have occurred through impact or misuse.
4. Check that the O-ring on the male CPC connector (Fig: 3) is in place and not damaged or cracked.
5. Check around the edges IEC socket and the IEC socket itself for damage that may have occurred through impact or misuse. (fig: 3).

Power Cable

1. Thoroughly check the full length of the power cord for any damage such as brittleness or splits.



IF THE POWER CABLE IS DAMAGED IN ANY WAY, DO NOT CONNECT THE POWER UNIT TO ANY POWER SUPPLY UNTIL A NEW POWER CABLE HAS BEEN FITTED

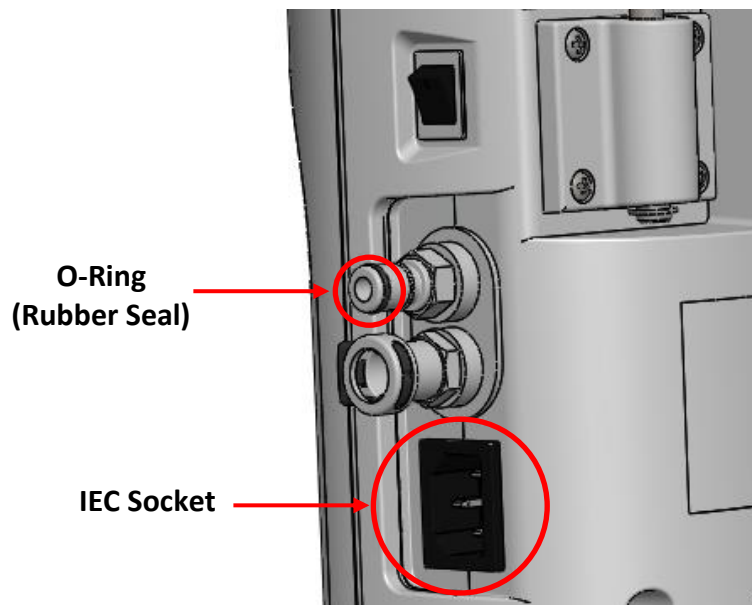

Fig: 3

Abnormal Noise

If the power unit makes abnormal noise during operation, such as grinding, rattling or excessive compressor noise or vibration, switch off and unplug the power unit. The power unit must be repaired before it can be used again.



DO NOT USE A POWER UNIT THAT IS MAKING AN ABNORMAL NOISE AS FURTHER DAMAGE OR ELECTRICAL FAILURE MAY OCCUR

D. General Cleaning Instructions



ALWAYS UNPLUG THE POWER UNIT BEFORE CLEANING



NEVER SPRAY LIQUIDS DIRECTLY ONTO A POWER UNIT



NEVER IMMERSE A POWER UNIT IN ANY LIQUID

Routine Cleaning During Use

1. Dampen a clean cloth with soap and water or a mild, neutral detergent and then wipe the power unit.

Routine Decontamination Between Patients

1. Dampen a clean cloth with soap and water or a mild, neutral detergent and then wipe the power unit.
2. Disinfect the power unit with hospital grade registered disinfectant. Let the power unit stand for the appropriate contact time, according to the manufacturer's instructions.
3. Dry the power unit using a clean, dry cloth or disposable paper towels.
4. Wrap the power unit in plastic and store in a cool, dry place.

E. Air Inlet Maintenance

It is recommended that the air inlet is serviced annually.

1. The air filter is on the rear of the unit, press in both the air filter cover tabs together and lift the air filter cover from the casing. (Fig: 4)
2. Remove the cotton filter. (Fig: 4)
3. Wipe any dust from the air filter cover and pump casing using a dry cloth.
4. Place a new cotton filter into the air filter cover and place it back into the casing, ensuring that the notch in the air filter cover lines up with the peg in the casing. (Fig: 4)
5. Press on each of the air filter cover tabs so that it snaps back into place.

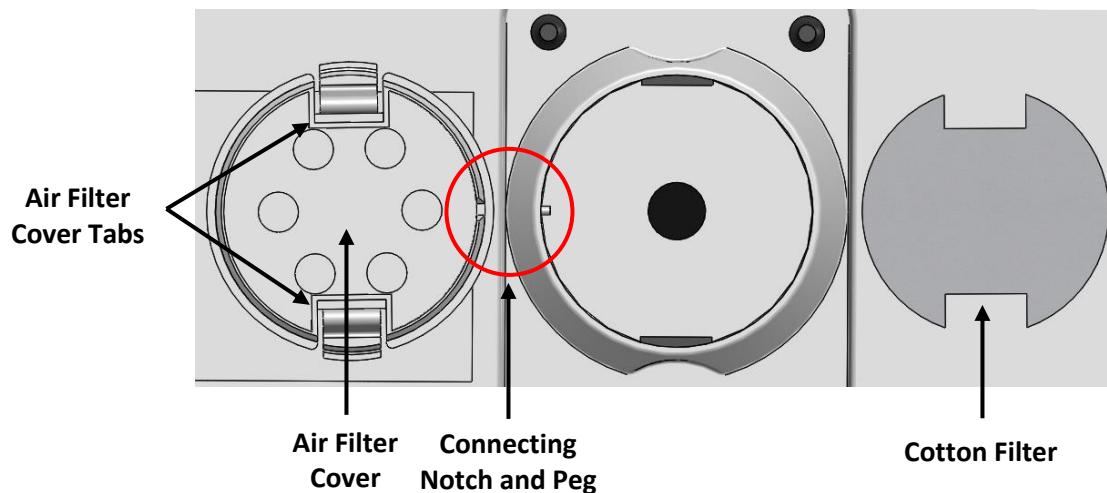

Fig: 4

F. Replacing Panel Foil



NEVER SPRAY LIQUIDS DIRECTLY ONTO A POWER UNIT



IF LIQUID IS ALLOWED INTO THE CASING OF THE POWER UNIT, EXTENSIVE DAMAGE MAY RESULT

1. The panel foil is held in place by a self-adhesive backing. Use a small, thin, flat bladed knife to pry up an edge and gently pull the panel foil to remove it.
2. Clean the surface thoroughly to remove any excess adhesive that may remain on the body case.
3. Remove the backing material from the new panel foil and position it on the pump casing. Slowly roll down the new panel foil pressing firmly on the entire surface to ensure full adhesion.

G. Replacing a Fuse



ALWAYS UNPLUG POWER UNIT BEFORE CHANGING THE FUSES

1. Push and turn the fuse holder counter clockwise, the fuse holder will pop up on its own. (Fig: 5)
2. Remove and replace the fuse with a fuse of the correct rating (20mm T1A).
3. Place the fuse holder into the power unit casing and gently push it down and turn it clockwise so that it locks into place.



Fig: 5

H. Replacing a Hanging Hook

1. Remove the four screws from the hanging hooks and then remove the hanging hooks from the power unit. (Fig: 6)
2. Place a new hanging hook into the hanging hook slot, fitting it securely and then place the hanging hook retaining plates into the retaining plate slots so that they fit securely.
3. Replace the four screws into the hanging hook retaining plates and tighten them.

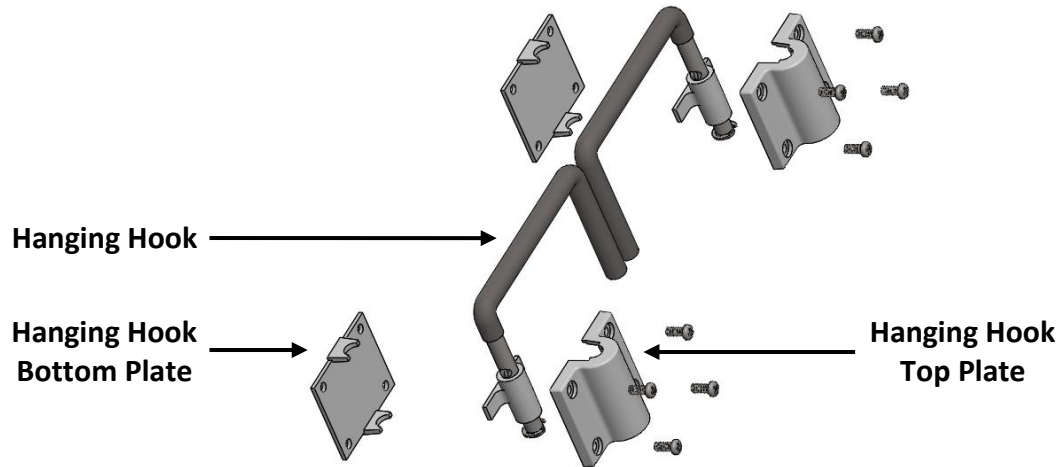

Fig: 6

Maintenance and Repair - Level 2

A. Introduction

The procedures described in Maintenance and Repair – Level 2 must only be carried out by manufacture-authorized service personnel. If your system cannot be repaired using the instructions in the Level 1 sections of this manual and you are not a manufacture-authorized service person, please contact Carilex Medical Inc. regarding repairs.

Be sure to seal the power unit with a new Do Not Open sticker after carrying out any of the procedures designated Level 2 and fill out a Product Service Record and email to Carilex Medical Inc. or to your distributor.

B. Tools Required

Philips PH2 Screwdriver



Wire Cutters



Sharp Knife



Small Flat Screwdriver



Small Pliers



Silicone Oil



Cleaning Alcohol



Lacquer



Superglue



ONLY FACTORY APPROVED PERSONNEL ARE AUTHORIZED TO USE THE REPAIR SECTION OF THIS MANUAL

Power Unit

A. Part Identification Overview

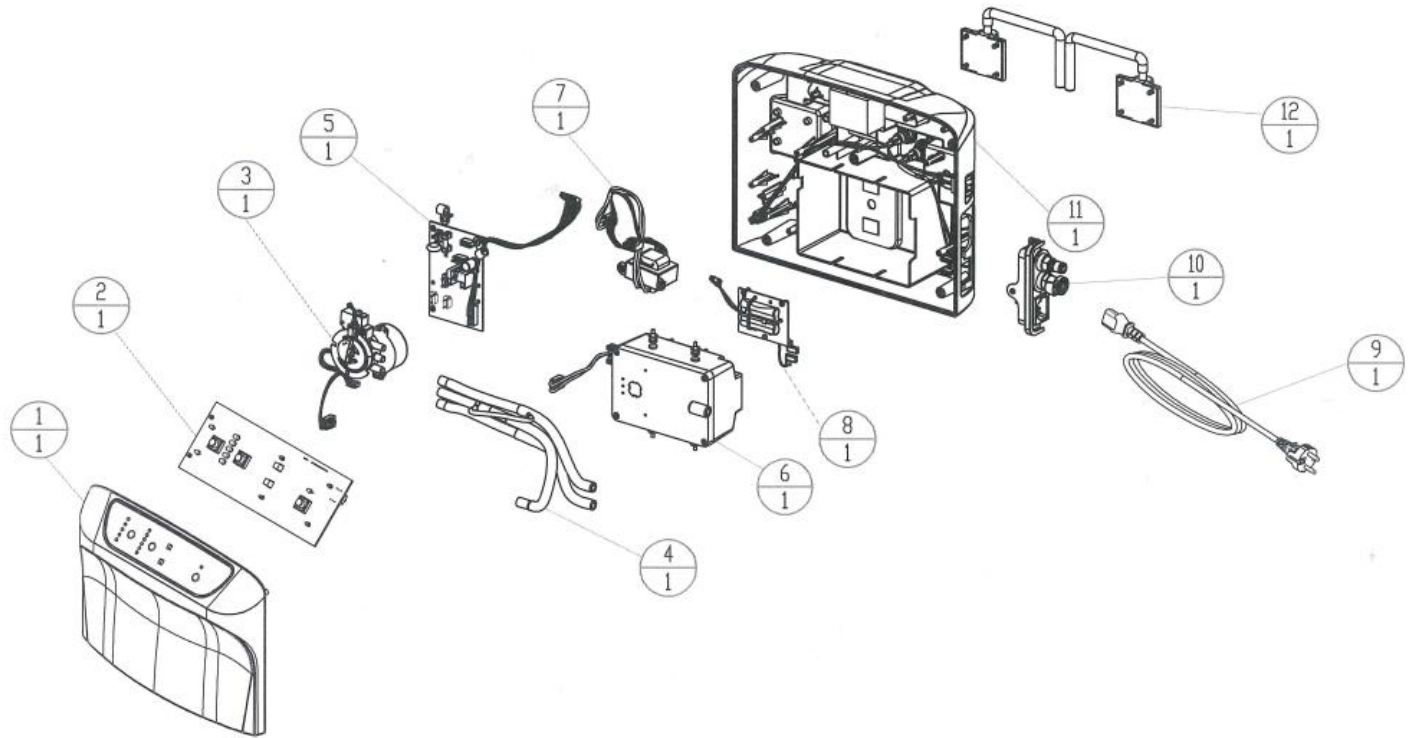

1. Top Case
2. Control PCBA
3. Rotor Valve
4. Silicone Tube Set
5. Power PCBA
6. Compressor
7. Transformer
8. Battery Set
9. Power Cable
10. Side Panel Set
11. Bottom Case
12. Hanging Hooks

B. Replacing the Top Case

1. Gently break the “Do Not Open” seal with a sharp knife.
2. Remove the five screws from the rear of the power unit. (Fig: 7)
3. Remove and layover the top case taking care not to pull on the silicone tube and wires. (Fig: 8)
4. Remove the 8-pin connector, 2-pin battery connector and pressure sensor silicone tube from the control PCB.
5. Remove the six screws from the control board and set the control board and the white buttons, found in the top case, aside. (Fig: 9)
6. Reverse the procedure to install the new unit, ensuring that the wire and silicone tube routing is exactly as found.



ALWAYS DISCONNECT THE POWER CABLE FROM THE POWER UNIT BEFORE CARRYING OUT REPAIRS ON THE POWER UNIT



TAKE CARE NOT TO TRAP ANY WIRES OR SILICONE TUBES BETWEEN THE TOP AND BOTTOM CASES AS THIS MAY RESULT IN MALFUNCTION OF THE POWER UNIT



To avoid electrostatic discharge, ground yourself by using a wrist grounding strap or by periodically touching an unpainted metal surface, such as the back panel of your computer.

IMPORTANT – Be sure to place a new Do Not Open sticker onto the underside of the power unit and fill out a Service Record Form (found at the end of this manual) and fax/mail to Carilex or Your distributor.

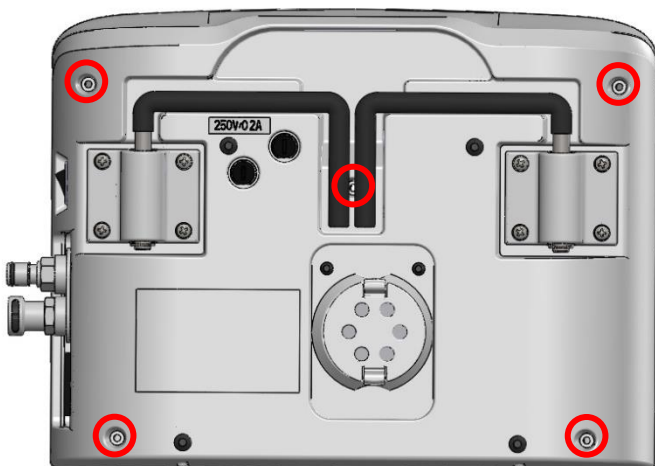

Fig: 7

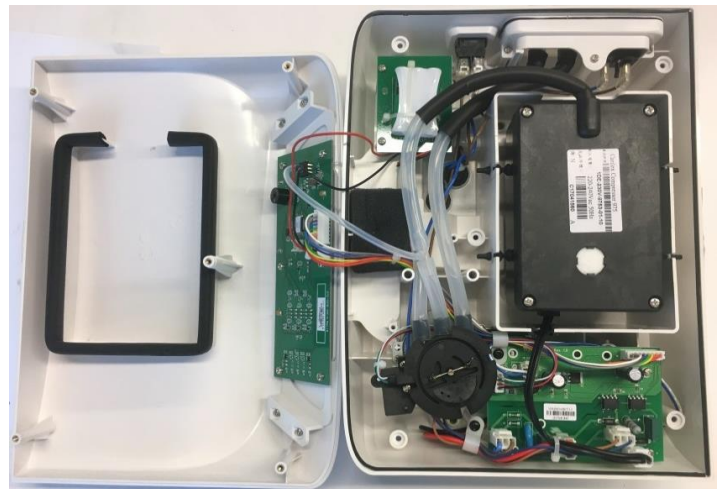
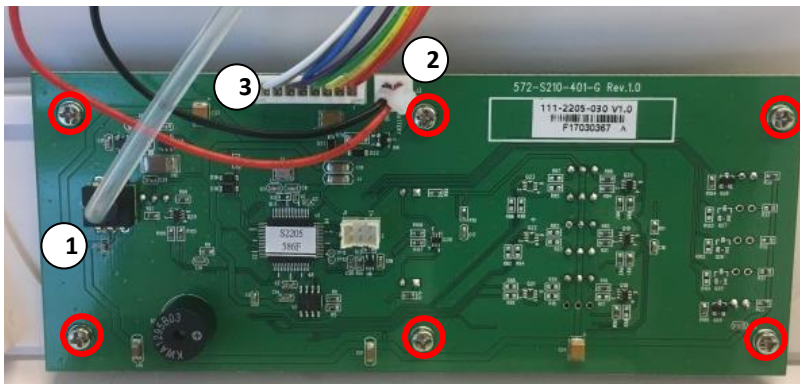

Fig: 8

ONLY FACTORY APPROVED PERSONNEL ARE AUTHORIZED TO USE THE REPAIR SECTION OF THIS MANUAL

C. Replacing the Control PCBA

1. Follow the steps in “Replacing the Top Case” to remove the top case.
2. Remove the six screws from the control PCBA. (Fig: 9)
3. Disconnect tube from pressure sensor. (Fig: 9)
4. Disconnect both 8-pin power PCBA connector and 2-pin battery connector. (Fig: 9)
5. Gently lift out the control PCBA, taking care not to disturb the white plastic switch buttons.
6. Reverse procedure to install new unit, ensuring that wire and silicone tube routing is exactly as found and taking care not to over-tighten the screws.



1	Pressure Sensor Tube
2	2-Pin Battery Connector
3	8-Pin Power PCBA Connector

Fig: 9

D. Replacing the Rotor Valve Assembly

1. Follow the steps in “Replacing the Top Case” to remove the top case.
2. Remove the one black screw from the cable tidy on the power PCB and then remove the one black screw from the other cable tidy, on the post near the power PCBA. (Fig: 11)
3. Cut the cable tie holding the compressor, transformer mains supply and the rotor valve motor wires if applicable and then remove the rotor valve sensor wire and rotor valve motor wire from the cable tides.
4. Disconnect rotor valve sensor and rotor valve motor from power PCBA. (Fig: 11)
5. Remove the three silicone tubes from the rotor valve, taking note of their fitting position on the rotor valve. (Fig: 10)
6. Turn the black rotor valve lower plate so both motor retaining screws are visible and remove the two screws.
7. Lift out rotor valve assembly.
8. Reverse procedure to install new unit, ensuring that wire and silicone tube routing is exactly as found. (Fig: 10)

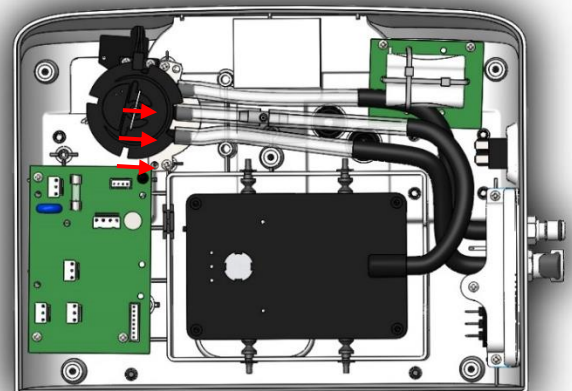

F: 10

E. Re-lubricating the Rotor Valve

- *We recommend that after 6 months of use, the rotor valve should be serviced with silicone oil.*
 - *We recommend that the rotor valve should be serviced with silicone oil before use if it has been standing idle for more than 3 months.*
1. Follow the steps in “Replacing the Top Case” to remove the top case
 2. Place a small screwdriver under the pin on the top plate of the rotor valve, push down on the rotor valve top plate and gently lever down on the screwdriver to break the lacquered seal.
 3. Push down on the rotor valve top plate and remove the pin.
 4. Carefully remove the top plate avoiding contact with the photo sensor.
 5. Thoroughly clean the top and lower plates with IPA alcohol or similar substance.
 6. Sparingly re-lubricate the bottom plate with silicone grease.
 7. Reverse steps 3 and 4 to replace the rotor valve top plate and reseal the ends of the pin using lacquer.



DO NOT USE ANY OTHER TYPE OF LUBRICANTS(SILICONE OIL) AS THIS MAY DAMAGE THE ROTOR VALVE PLATES AND MOTOR



WE RECOMMEND THAT AFTER 6 MONTHS OF USE, THE ROTOR VALVE SHOULD BE SERVICED WITH SILICONE OIL



WE RECOMMEND THAT THE ROTOR VALVE SHOULD BE SERVICED WITH SILICONE OIL BEFORE USE IF IT HAS BEEN STANDING IDLE FOR MORE THAN 3 MONTHS

F. Replacing the Silicone Tube Set

1. Follow the steps in “Replacing the Top Case” to remove the top case.
2. Remove the three silicone tubes from the rotor valve (Fig: 10) and the one narrower tube from the pressure sensor. (Fig: 9)
3. Reverse procedure to install new unit. The three silicone tubes run between two plastic posts in the rear outer case, with the nearest tube to the battery set running under the corner of the battery set board.

G. Replacing the Power PCBA

1. Follow the steps in “Replacing the Top Case” to remove the top case.
2. Remove the four power PCBA retaining screws, three silver screws and one black screw with cable tidy. (Fig: 11)
3. Lift out power PCBA.
4. Reverse procedure to install new unit, referring to Fig: 11 for the positions of the connectors, ensuring that the wire routing is exactly as found.

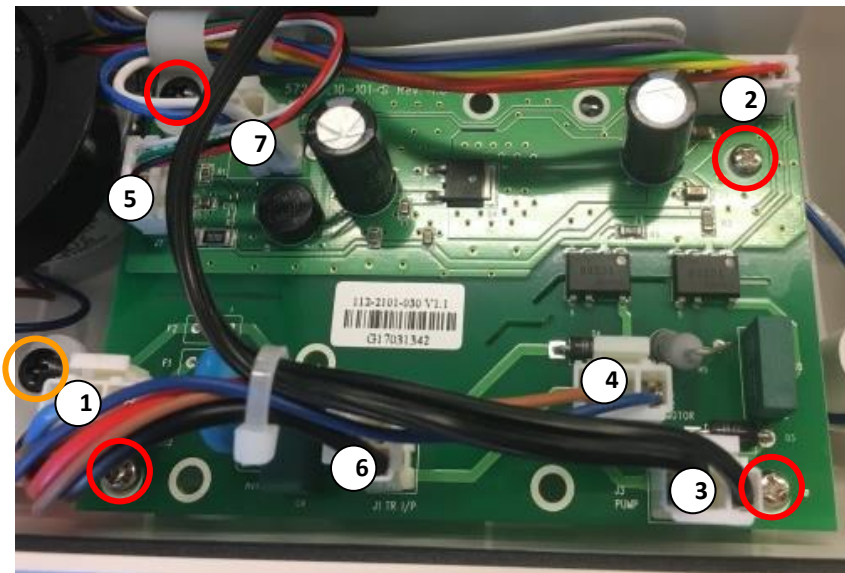

Fig: 11

1	AC Power Connector
2	Control PCBA Connector
3	Compressor Connector
4	Rotor Valve Motor Connector
5	Rotor Valve Photosensor Connector
6	Transformer Input Connector
7	Transformer Output Connector

H. Replacing the Compressor

1. Follow the steps in “Replacing the Top Case” to remove the top case.
2. Disconnect 2-pin compressor connector from Power PCBA. (Fig: 11)
3. Disconnect silicone tube from the compressor. (Fig: 12)
4. Remove the four black suspension rubbers on the sides of the compressor from the power unit casing. (Fig: 12)
5. Turn the unit over and gently pull on the compressor whilst carefully using a pair of needle nose pliers to push the four remaining suspension rubbers through the power unit casing. (Fig: 13)
6. Gently pull the compressor upward to remove compressor from the power unit casing.
7. Reverse procedure to install the new compressor, using the needle nose pliers to replace the suspension rubbers in the bottom case and ensuring that wire and silicone tube routing is exactly as found.

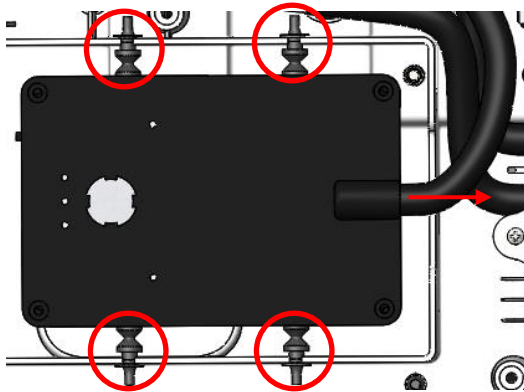

Fig: 12



Fig: 13

I. Replacing the Transformer

1. Follow the steps in “Replacing the Top Case” to remove the top case.
2. Follow the steps in “Replacing the Power PCBA” to remove the Power PCBA.
3. Remove the one black screw from the cable tidy, holding the rotor valve motor wires and the transformer mains supply wires. (Fig: 11)
4. Remove the transformer mains supply wires and the transformer output wires from the cable tidies.
5. Cut the cable tie holding the compressor, transformer mains supply and the rotor valve motor wires if applicable.
6. Remove the two transformer retaining screws and then lift out transformer. (Fig: 14)
7. Reverse procedure to install new unit, ensuring that wire routing is exactly as found.

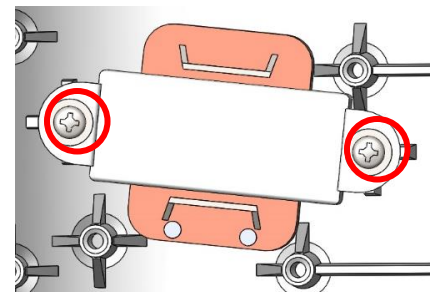

Fig: 14

ONLY FACTORY APPROVED PERSONNEL ARE AUTHORIZED TO USE THE REPAIR SECTION OF THIS MANUAL

J. Replacing the Battery Assembly

1. Follow the steps in “Replacing the Top Case” to remove the top case.
2. Remove the three screws from the battery retaining plate. (Fig: 15)
1. Disconnect the two battery wires from the rocker switch. (Fig: 15)
2. Disconnect the 2-pin battery wire from the control PCBA. (Fig: 9)
3. Remove battery pack.
4. Reverse procedure to install new unit, ensuring that the wire routing is exactly as found.

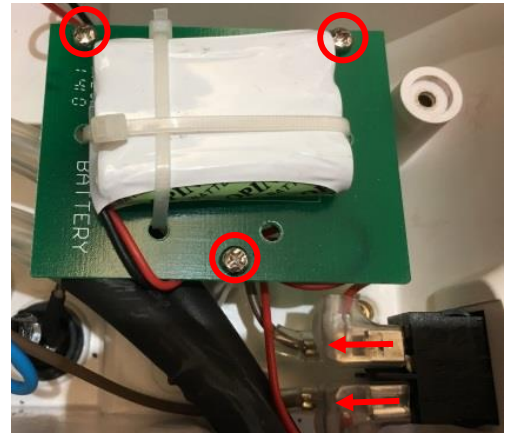

Fig: 15

K. Replacing the Side Panel Set

1. Follow the steps in “Replacing the Top Case” to remove the top case.
2. Using a manual screwdriver, carefully remove the three screws from the side panel. (Fig: 16)
3. Lift the side panel out to give access to the IEC socket and CPC assembly. (Fig: 17)
4. Remove and replace IEC socket and CPC assembly as needed.
5. Reverse the procedure to install new unit ensuring that the wire and silicone tube routing is exactly as found.

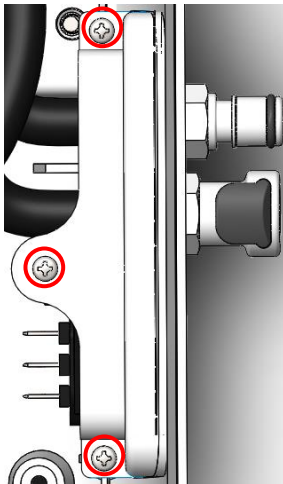

Fig: 16

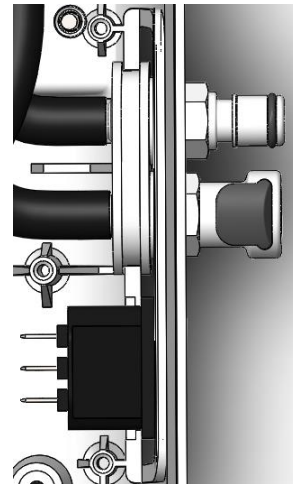

Fig: 17

ONLY FACTORY APPROVED PERSONNEL ARE AUTHORIZED TO USE THE REPAIR SECTION OF THIS MANUAL

L. Replacing the Bottom Case

1. Follow the steps in “Replacing the Hanging Hooks” to remove the Hanging Hooks from the bottom case.
2. Follow the steps in “Replacing the Top Case” to remove the top case.
3. Follow the steps in “Replacing the Rotor Valve Assembly” to remove the Rotor Valve Assembly from the bottom case.
4. Follow the steps in “Replacing the Power PCBA” to remove the Power PCBA from the bottom case.
5. Follow the steps in “Replacing the Compressor” to remove the Compressor from the bottom case.
6. Follow the steps in “Replacing the Transformer” to remove the Transformer from the bottom case.
7. Follow the steps in “Replacing the Battery Assembly” to remove the Battery Assembly from the bottom case.
8. Follow the steps in “Replacing the Side Panel Set” to remove the side panel set from the bottom case.
9. Using a small, thin, flat-bladed knife, lift the corner of the information sticker (Fig: 18) on the bottom case and pull it away gently.
10. Reverse the procedure to install the new bottom case, ensuring that the information sticker (Fig: 18) is replaced securely using superglue if required and that the wire and silicone tube routing is exactly as found.

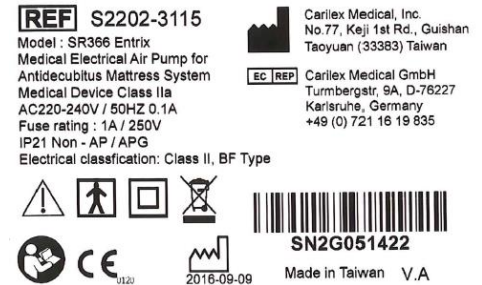

Fig: 18

Testing

A. Introduction

The procedures described in this section of the manual can be carried out by any trained member of staff.

B. Tools Required

Service Kit

CPC Adapter



Power Unit

A. Function Test

Stage	Steps
Power On	<ul style="list-style-type: none"> • Plug the power cable into the wall socket • Switch the wall socket on • Switch the rocker switch on the power unit on • Press the Power/Mute button on the power unit to switch it on
Initial	<ul style="list-style-type: none"> • The lights on the control panel will all switch on, the power light will flash and the compressor will be pumping • The compressor will switch off • When the compressor switches on again, the mode, weight setting , pressure monitoring and power LEDs will be on
Dynamic	<ul style="list-style-type: none"> • Attach a CPC assembly to the CPC assembly on the underside of the pump • Press on the pipe that has air coming from it to block the air • The compressor will switch off, remove your finger from the pipe • When the compressor switches on again, press on both pipes to block the air coming from them • The compressor will switch off, remove your fingers from the pipes • When the compressor starts again it will be pumping air through only one of the air outlets
Comfort Settings	<ul style="list-style-type: none"> • Use the Comfort button to cycle through the Comfort settings • The Comfort setting LEDs will cycle from bottom to top
Mode Settings	<ul style="list-style-type: none"> • Press the mode button • The CLP Therapy (static mode) LED will light and the compressor will pump air through both outlets • Press the mode button • The Max Inflate led will light and the compressor will pump air through both outlets • Press the mode button • The dynamic mode LED will light and the compressor will pump air through one of the outlets
Alarm	<ul style="list-style-type: none"> • Pull the power cable from the wall socket during operation • The alarm will sound and the power light will go red • Press the Power/Mute button to silence the alarm • Replace the power cable into the wall socket to return the power unit to the initial stage
Power Off	<ul style="list-style-type: none"> • Press the Power/Mute button to switch the power unit off • Switch the rocker switch off to disconnect the power supply and battery set from the power unit

B. Flow Test

The following test procedures can be used to check the airflow from the power unit:

1. Power up the unit and set it to static mode using “Function Test.”
2. Power up and connect the flow meter to one of the tubes in the CPC assembly and then place a finger over the tube to stop the air from flowing from it. (Fig: 19)
3. Take note of the reading on the flow meter. (Fig: 20) If the flow is less than 6.5 L/min then the power unit may require servicing.

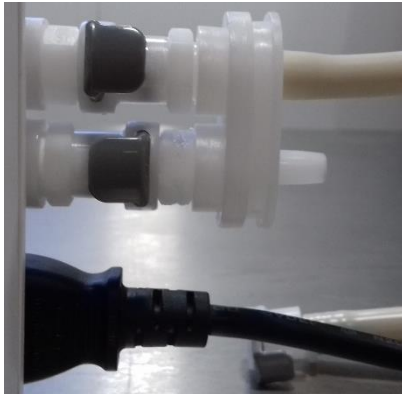



Fig: 19





Fig: 20



Fig: 21

 The minimum flow in this test is based on the TIC TF601-D flow meter as found in the Carilex Service Kit. Flow readings may vary between different flow meters and configurations.

 When taking a reading from the flow meter, ensure that its silicone tube is not kinked. (Fig: 21)

 Ensure that all meters used in testing are properly calibrated.

Troubleshooting

A. Introduction

The procedures described in Troubleshooting that are marked Level 2 must only be carried out by manufacture-authorized service personnel. All other procedures in described in Troubleshooting can be carried out by any trained maintenance personnel.

If your system cannot be repaired using the instructions in the Level 1 sections of this manual and you are not a manufacture-authorized service person, please contact Carilex Medical Inc regarding repairs.

B. Power Unit

No Lights on Power Unit	No Airflow from Power Unit	Excessive Noise from Power Unit	Excessive Vibration from Power Unit	Troubleshooting Guidelines
★	★			<ul style="list-style-type: none"> • Check that the wall socket is working • Check that the power unit's rocker switch is on • Check that the power cable is plugged into the wall socket • Check the fuses in the power cable and in the power unit • Level 2: Check that all internal wires are connected and not broken • Level 2: Check the fuse on the power PCBA
★				<ul style="list-style-type: none"> • Level 2: Change the control PCBA for a new one and check its function using "A: Function Test" • Level 2: Change the power PCBA for a new one and check its function using "A: Function Test"
	★			<ul style="list-style-type: none"> • Check the CPC assembly for blockages • Level 2: Check the compressor using "B: Flow Test" • Level 2: Check that all internal wires are connected and not broken • Level 2: Check that all internal tubes are connected and not punctured • Level 2: Check that the rotor valve turns and stops according to "A: Function Test"
		★	★	<ul style="list-style-type: none"> • Level 2: Check that the compressor is correctly mounted in the bottom case • Level 2: Check the compressor bellow block for wear • Level 2: Unplug the compressor from the Power PCBA and check the rotor valve for noise when it is turning
		★		
			★	



ENSURE THAT THE POWER SUPPLY IS NOT CONNECTED TO THE POWER UNIT BEFORE OPENING THE POWER UNIT CASE



ENSURE THAT THE POWER UNIT CASE IS CLOSED AND SCREWED TOGETHER BEFORE CONNECTING THE POWER SUPPLY



Product Service Record

F101.04

General Information			
Date:			
Service Technician:			
Company:			
Location:			
Product Serviced:			
Serial Number:			
Device Article Number:			
Invoice Number:			
In Warranty:	Yes / No		
General Problems Description:			
Parts Replaced or Repaired	Problems Identified	Serial Number (Record if applicable)	Function Test
		Old: New:	Follow Service Manual: NO. _____ Result: <input type="checkbox"/> PASS <input type="checkbox"/> NG
		Old: New:	
		Old: New:	
		Old: New:	
<p>For Carilex QA Division use only: 類別：A: 硬體設計類 B:軟體設計類 C:機構設計類 D:製造品質 E:檢驗品質 F: 供應商品質 G:其他</p> <p>是否建議開立 ECR <input type="checkbox"/>No. <input type="checkbox"/> Yes, ECR/ECN# _____</p> <p>是否建議開立 Customer Complain</p> <p><input type="checkbox"/>No(Consumables/ User error/ others _____).</p> <p><input type="checkbox"/>Yes(Abnormal function/ Volume of abnormal quality/ others _____), CC NO. _____</p> <p>For Carilex Sales Div. use only: (已經超過保固期之維修費用請打 D/N 收款, 請在此記錄 D/N#)</p> <p>Device sent back to customer on _____ via _____</p> <p style="text-align: center;">(表格與 D.C.C 發行之最新版本相符)</p>			

ONLY FACTORY APPROVED PERSONNEL ARE AUTHORIZED TO USE THE REPAIR SECTION OF THIS MANUAL